

Project Name: \_\_\_\_\_ AIA#: \_\_\_\_\_

Model #: \_\_\_\_\_ Location: \_\_\_\_\_

SIS#: \_\_\_\_\_ Item #: \_\_\_\_\_ Quantity: \_\_\_\_\_



# 60 Quart Planetary Pizza Floor Mixer

**Robust size and power  
for handling pizza dough!**

*Features two fixed speeds and operator-friendly power bowl lift.*



## Model

SPC62P — Pizza Mixer

## Standard Features

- Powerful 3 HP custom built motor
- Gear-driven, high-torque transmission
- Heat-treated hardened steel alloy gears & shafts
- Two fixed speeds
- Handles up to 50 lbs. of flour (80 lb. batch size)
- Permanently lubricated oil bath transmission
- Thermal overload protection
- Front-mounted touch pad controls with 60-minute digital timer and last-batch recall
- Stainless steel, interlocking bowl guard with built-in, fully welded ingredient chute
- Safety interlocked power bowl lift
- Heavy duty bowl truck (pictured)
- Rigid cast iron body
- Industry standard #12 attachment hub
- NSF approved enamel gray paint
- 6-foot cord and ground plug
- Auto shut off, for operator safety plus motor and transmission protection

## Standard Accessories/Attachments

- 60-qt. stainless steel bowl (#304 series)
- Aluminum spiral dough hook
- Non-slip rubber feet
- Bowl truck

## Warranty

- Two years parts and labor

## Optional Attachments/Accessories

- Seismic flange kit
- Slicer/shredder/grater for #12 hub
- Meat grinder for #12 hub
- Meat tenderizer for #12 hub
- Strip cutter for #12 hub
- Aluminum flat beater
- Stainless steel wire whip
- Additional bowl truck
- Correctional package

*To select options see back*

Approved by: \_\_\_\_\_ Date: \_\_\_\_\_

2153 Dryden Rd., Dayton, OH 45439 | 937-299-5493 | 800-347-5423 | Fax: 937-299-4147 | [www.globefoodequip.com](http://www.globefoodequip.com)



# 60 Quart Planetary Pizza Floor Mixer

# SPC62P

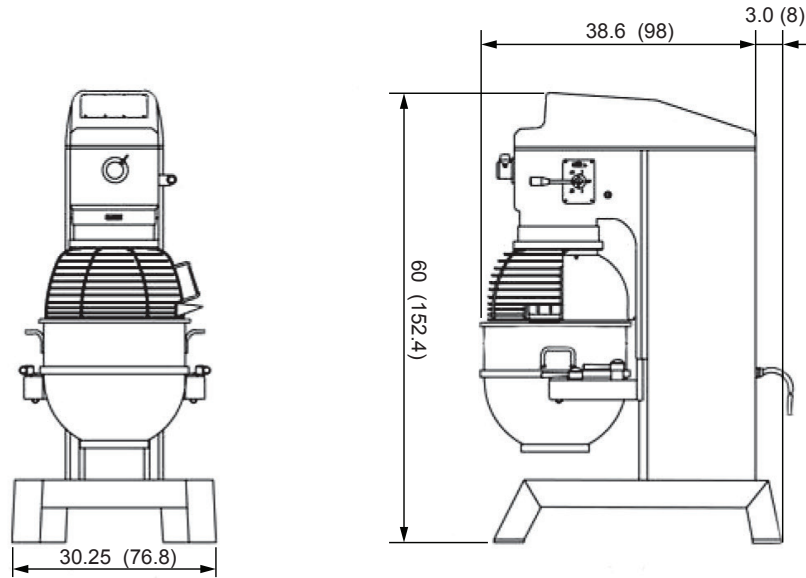

Drawings available through KCL at [www.kclcad.com](http://www.kclcad.com).

## SPECIFICATIONS

Model	Motor	Volts	Amps	Transmission Type	Capacity	Controls	Power Bowl Lift	Agitator Speeds (RPMs)		Attachment Speeds (RPMs)	
								First	Second	First	Second
<b>SPC62P</b> (1 Phase)	3 HP	220/60/1	18	Gear	60 qt / 57 liter	Digital, front mounted timer and controls	1/8 HP Motor	56	98	64	110
<b>SPC62P</b> (3 Phase)	3 HP	208/60/3	12	Gear	60 qt / 57 liter			64	110		

**Cord & Plug:** Attached 6-foot flexible 3-wire cord with molded plug fits a grounded receptacle. Single phase NEMA L6-20P (1) Three phase NEMA L15-20P (2)  
*\*Specify voltage when ordering.*

## DIMENSIONS | SHIPPING INFORMATION

Reinforced carton for shipping. The weight and dimensions of this reinforced carton are included below and may vary from shipment to shipment.  
**This product ships on a pallet. Freight class 85.**

Model	Overall Dimensions	Net Weight	Shipping Dimensions	Shipping Weight
<b>SPC62P</b>	30.25" W x 41.6" D x 60" H (76.83 cm x 105.66 cm x 152.4 cm)	980 lbs (444 kg)	48" W x 48" D x 76" H (122 cm x 122 cm x 193 cm)	1,228 lbs (556 kg)

Mixer is constructed of a rigid cast iron body with front-mounted controls and 60-minute digital timer. Mixer has 3 HP custom built motor with overload protection and gear-driven, high torque permanently lubricated 2 speed transmission consisting of heat-treated hardened steel alloy gears and shafts. Mixer comes with 60 qt. stainless steel bowl, stainless steel bowl truck and wire whip, aluminum dough hook and non-slip rubber feet. Interlocked with stainless steel bowl guard with fully welded ingredient chute. Mixer has #12 attachment hub and interlocked bowl lift. Mixer is NSF and ETL listed. Two-year parts and labor warranty.

## OPTIONAL MIXER ACCESSORIES AND HUB ATTACHMENTS

- MIXER:**
- XXSEISMIC KIT-LG** Seismic kit
  - XXBOWL-62** 60 qt. stainless steel (S/S) bowl
  - XXBEAT-62** Alum. flat beater
  - XXHOOK-62** Alum. dough hook
  - XXWHIP-62** S/S wire whip
  - XBTRUCK-62** Heavy-duty bowl truck
- HUB:**
- XVSGH 9"** Slicer/Shredder/Grater housing only (no plates included-must select from plates listed on this sheet)
  - XASP** Adjustable slicing plate (for vegetables only)
  - XPH** Plate holder
  - L00670** Meat Tenderizer attachment
  - L00783** Strip Cutter attachment
- Shredding Plates:**
- XSP332\*** 3/32" (2.3 mm)
  - XSP316\*** 3/16" (4.7 mm)
  - XSP14\*** 1/4" (6.3 mm)
  - XSP516\*** 5/16" (7.9 mm)
  - XSP12\*** 1/2" (12.7 mm)
  - XGP\*** Grating plate
- \*Only 1 plate holder required*
- XMCA-SS** Meat grinder assembly (Polished stainless steel cylinder, worm gear, ring, and s/s pan. Includes knife, 3/16" plate, and pusher.)
  - XXCK** Chopper knife for XMCA-SS
- Chopper Plate Sizes Available:**
- CP02-12** 1/16" (2 mm)
  - CP04-12** 5/32" (4 mm)
  - CP05-12** 3/16" (5 mm)
  - CP06-12** 1/4" (6 mm)
  - CP08-12** 5/16" (8 mm)
  - CP10-12** 3/8" (10 mm)
  - CP12-12** 1/2" (12 mm)
  - CP14-12** 9/16" (14 mm)
  - CP16-12** 5/8" (16 mm)
  - CP18-12** 11/16" (18 mm)
  - CP00-12** Stuffing plate
  - XST12** 1/2" Stuffing tube (mutton)
  - XST34** 3/4" Stuffing tube (pork)
- FACTORY INSTALLED OPTION: XXCORR-62** Correctional package, includes tamper resistant external fasteners.